



Weight Change Instrument MW93A

Technical Information ALL

ModWeigh

FEATURES

- **Flowrate measurement and control for loss-in-weight (or gain-in-weight) systems**
- **Motor Speed Control Output Signal**
- **Flowrate Output**
- **Material Totaliser**
- **Modbus communications (independent RS232 and RS485 ports)**
- **USB Host & Device (memory stick & PC)**
- **Field software upgrades**
- **12-24Vdc power supply**
- **Overall accuracy better than 0.01%**

MD2,MP2 INDICATOR

- **IP54 Facia**
- **2.8" (70mm) colour LCD**
- **320 x 240 pixels**
- **Polyester film tactile keypad**
- **4-20mA output, 1 digital input & 2 digital outputs**

MO3 I/O for MP2

- **4 Digital inputs**
- **4 Digital outputs**
- **4-20mA input (or 0-10V)**
- **4-20mA output**

MD1,MP1 INDICATOR

- **IP65 Facia**
- **4.3" (109mm) colour LCD**
- **480 x 272 pixels**
- **Silicone tactile keypad**

MT1 TRANSMITTER

- **Size 136 x 66 x 50mm**
- **Optional removable P-Module holds calibration settings**



MT3 TRANSMITTER

- **Size 136 x 66 x 50mm**

MR1 I/O

- **Size 136 x 66 x 30mm**
- **8 Digital inputs**
- **8 Digital outputs**
- **4-20mA input (or 0-10V)**
- **4-20mA output x 2**
- **Pulse output**

Application

A ModWeigh MW93 Weight Change System is used to control the flowrate of material passing through a weigh hopper and flow regulator. Common flow regulators used for these systems are augers or rotary valves.

The processor is suitable for systems where the flow regulator removes material from a weigh hopper (weight loss system) and systems where the flow regulator adds material to the weigh hopper (weight gain system).

ModWeigh Display

A ModWeigh Flowrate Indicator is used to calibrate the system and provide a status display of the operating system. It has a graphics display with easy to use menu selection of settings.

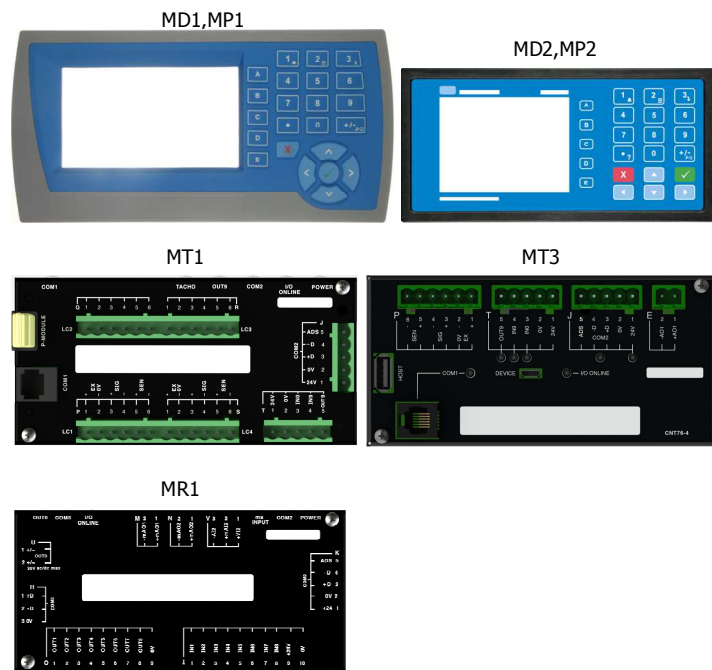
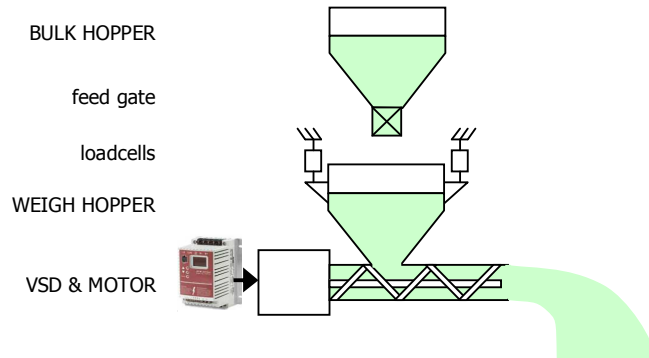

Features

Basic

Units & Resolution

The units for each variable type (weight etc.) can be selected from a list of metric and imperial units. The resolution of each variable type can be adjusted, this alters the count by e.g 100kg displayed in 0.2kg increments.

OIML Design

The instrument is designed to OIML standards.

Language Support

Support is available for the following languages: English, Chinese, Korean, German, Spanish, French, Italian and Polish.

Inputs

Digital Inputs INx

The digital inputs are programmable to a range of function including 'acquire zero', 'print' etc.

Direct Calibration

Direct calibration uses the loadcell capacity and loadcell sensitivity to calibrate the weight signal. Large capacity weighing systems can be quickly and accurately calibrated without the need for large test weights.

Corner Adjustment (MT1 only)

The input sensitivity can be individually adjusted for up to 4 loadcells, allowing differences in loadcell sensitivities to be corrected.

Four Loadcell Inputs (MT1 only)

Separate inputs are available for 4 loadcells allowing the signal of each to be monitored separately. This provides an aid for load balancing across loadcells and also for fault finding.

Flowrate Setpoint

The setpoint is the flowrate of material the operator wants the flow regulator to convey. The MW93 can control to the local setpoint, which is set using the keypad, or it can control to the optional remote analog setpoint signal. The second analog input AI2 is required for a remote analog setpoint.

Signal Filtering

Filtering for the weight can be adjusted to get the optimum compromise between reduction of plant vibration and response speed.

Internal Signals

Limits

The high and low limits have adjustable setpoints which may be programmed to operate on any internal signal.

Batching

The system can be used to batch out a desired weight by stopping the feeder when the batch weight has been totalised. A pre-act is available to compensate for overrun.

Event Collection

Process events are collected for operation with external equipment (PLCs etc.)

Loop Control

The processor compares the flowrate with the setpoint. A proportional/integral (PI) control technique with feed forward alters the motor speed demand signal to maintain the flowrate at setpoint. Feed forward allows the system to reach the desired set flowrate very quickly and also to respond to changes in setpoint rapidly.

Volumetric Mode

Normally the controller operates gravimetrically and automatically adjusts the speed demand signal to reach the required flowrate setpoint.

In volumetric mode, the PI control is disabled, and the speed demand is estimated using the feed forward settings.

This allows the system to be kept operating even in the event of a loadcell failure.

Advanced Control Settings

Feed forward settings can be adjusted and corrections for plant delays (transport delay) can be made. A ratio setting is available to multiply the setpoint signal by a percentage for ratio control applications.

Hopper Refilling

The processor uses weight setpoints and delays to produce a material feed control signal. In a weight loss system, the feed is opened to refill the weigh hopper from bulk storage when it nears empty. In a weight gain system, the feed is opened to empty the weigh hopper when it nears full. During the filling process, the processor is put into hold during which the flowrate reading and the motor speed demand

signal are held constant. This keeps the flow regulator speed constant during refilling when the flowrate can not be measured.

Automatic Hold

The hopper weight is continuously monitored to automatically detect that filling is occurring or that the hopper has been accidentally knocked. If this is detected, the flowrate signal and speed demand signal are held constant until the weight returns to normal. This feature ensures that a constant output flowrate is always maintained during a disturbance to the hopper.

Auto Setup

To make setting up easier, the auto setup facility allows many settings for the processor to be calculated and set automatically.

Memory Storage

Allows a group of settings to be stored or recalled from memory. This can be used for example to store settings for different products. There are 20 memory locations with up to 4 settings in each.

Material Total

The processor incorporates a totaliser which totalises the weight of material through the system. The totaliser can be reset to zero. A pulse output is available to operate external counters. A low flow cutout ensures that low flows do not cause false counts. The total is retained after a power failure.

The totaliser can be set to operate with 5, 6, 7 or 8 digits.

Outputs

Speed Demand

An analog speed demand output signal is used to drive an externally connected motor controller to vary the flow regulator speed.

Material Flowrate

An analog flowrate output signal is available for connection to other instruments.

Analog I/O Scaling

The analog output range can be adjusted over the full 0 to 20mA range. The output will drive to a slight negative mA, allowing a live zero to be achieved when using a 0 to 20mA range. A voltage output is easily produced by connecting a resistor to the output.

In addition the analog output signal is selectable to come from any internal signal in the instrument e.g weight, flowrate etc.

Digital Outputs OUTx

The digital outputs are programmable to operate from any internal signal. These signals include the digital input states, status conditions (running, paused etc) and any fault conditions that are detected. This makes it easy connect into other systems.

Communications & Display

Comms

RS232 and RS485 ports are available. These are used to connect ModWeigh units together and also to connect to other systems. The protocol is either ASCII output for example to drive a printer or Modbus for interactive communications. Baud rates and node addresses are programmable.

USB host and device ports are available. This allows for example PC and USB flash drive connectivity. It can be used to update the units software, for data logging and for recording of the units settings.

Printouts & Macros

Printouts can be triggered by a key press or set up to occur at set times during the day or week. Data may also be output continuously for data collection purposes. Data is output on the COM1 RS232 port. The content of the printouts is fully programmable using Macros.

Macros are programs used to customise printouts, but can also be used to perform arithmetic calculations. The Macro language also contains conditional terms for more advanced programming.

Display Customisation

Locks may be set to prevent unauthorised use of the operator keys and restrict entry to the operator menu. The keys are individually lockable and optionally a passcode can be used to allow authorised operators to use the keys. Alternatively a confirmation of the key action can be requested. The operator MENU can be customised to make additional settings or signals available to the operator.

The contents of the main display can be set to suit any condition, from a comprehensive display showing all operating parameters to a simple display showing the basic signals.

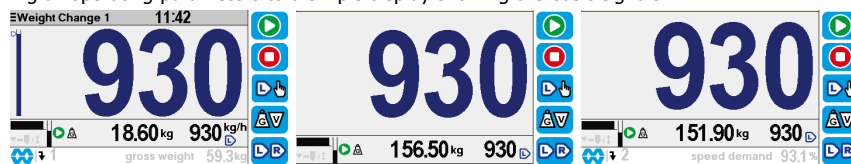

Computer Connectivity

ModWeigh instruments can be connected to a computer with an RS232 connection. Data can be sent to the PC at a preset rate. The data sent can be set up using macros.

There is also a command line interface which allows any of the settings and data to be read or written.

IO Summary

	Digital Inputs (includes pulse input)	NAMUR pulse input option	Digital Outputs (includes pulse output)	Isolated Pulse Output	Isolated 4-20mA Inputs	Isolated 4-20mA Outputs	RS232	RS485	USB Host (Memory Stick)	USB Device (PC Cable)	Corner adjustment and balancing for 4 loadcells	Trade approvals (MW95, MW96)
MP2	1	*	2	1	0	1	1	1	1	*	*	
MP2,MO3	1+4	*	2+4	1	1	1+1	1	1	1	*	*	
MP1,MR1	1+8	*	9	1	1	2	2	1	1	*	*	
MD1,MT1,MR1	2+8	✓	1+9	1	1	2	2	2	1	1	✓	
MD2,MT1,MR1	2+8	✓	1+9	1	1	2	2	2	1	1	✓	
MD1,MT3	2	*	1	0	0	1	2	1	1	1	*	
MD2,MT3	2	*	1	0	0	1	2	1	1	1	*	
MD1,MT3,MR1	2+8	*	8	1	1	3	2	1	1	1	*	
MD2,MT3,MR1	2+8	*	8	1	1	3	2	1	1	1	*	

Configurations

There are three principle configurations for gravimetric flow measurement and control systems. These are Weight Loss, Modified Weight Loss and Weight Gain.

All configurations have the same basic components of a flow regulator and weigh hopper.

Weight Loss

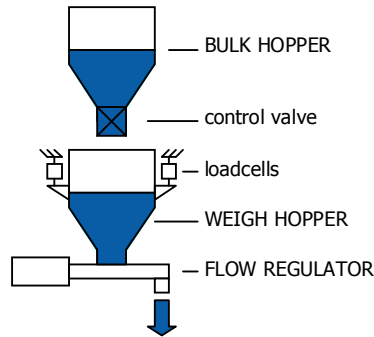

Features

- continuous flow
- weigh hopper & flow regulator combined

Modified Weight Loss

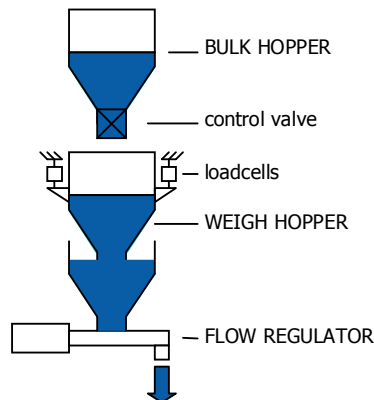

Features

- continuous flow
- weigh hopper isolated from flow regulator combined e.g. plastic extruders



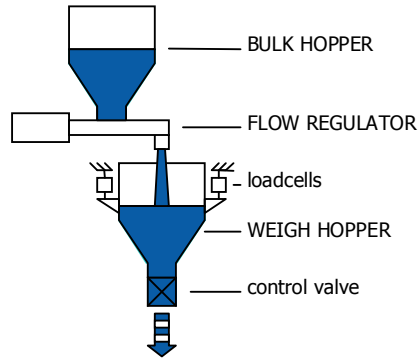

Weight Gain

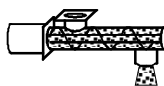

Features

- interrupted flow
- simple installation
- ideal where bulk hopper & feeder already exist

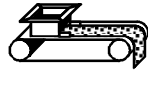
Flow Regulators

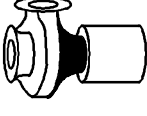
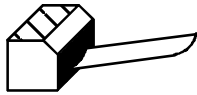
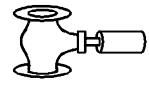
 SCREW FEEDER	 DRUM FEEDER
 BELT FEEDER	 TABLE FEEDER
 ROTARY VALVE	 PUMP
 VIBRATOR FEEDER	 RESTRICTOR VALVE

Performance

One factor which determines the performance of a system is the capacity of the loadcell weighing system used to weight the hopper. The following graph gives an indication of the useful operating range that may be used. The Loadcell Capacity is the sum of the capacity of all loadcells, and should take into account any lever system if one exists.

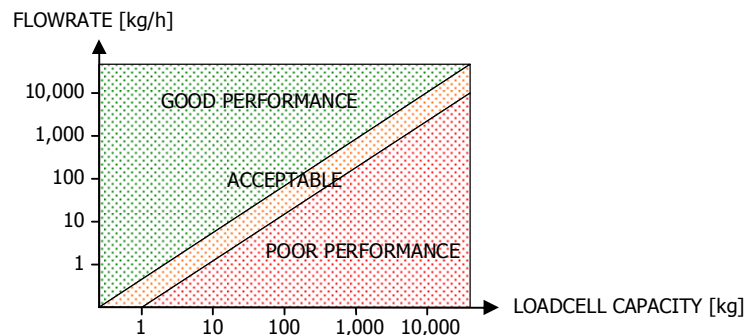

The performance is very dependent on the weighing system repeatability. It is desirable to aim for as high a repeatability as possible. With care, it is possible to achieve weighing repeatability of 1 part in 10,000 to 1 part in 100,000.

Note that other factors may also limit the performance.

Watch flexible couplings to the weigh hopper, as these can easily reduce the achievable performance.

Good accuracy also requires repeatable results from the flow regulator system. Some materials can be difficult to control (for example powders that fluidise)

Specifications

Loadcell Input AI1

Input Range	±4 mV/V (0-20mV)
Excitation	5 Vdc ±20 %, 250 mA maximum current
Signal processing rate	100 Hz (response time setting ≤ 0.5 s)
Input sensitivity	0.5 μV/division maximum
Zero range	±3 mV/V (±15 mV)
Zero drift	±0.02 μV+0.0005 % of deadload/°C typical
Span drift	±0.0005 %/°C typical
Non-linearity	<0.002 % of FS
Input noise	0.15 μVp-p typical
Filtering	0.04 s to 32.0 s response time adjustable
Sense voltage range	1-5 V

Analog Input AI2

4-20mA input resistance	<60 Ω
0-10V input resistance	>100 kΩ
Isolation	galvanically isolated to 50Vac

Analog Outputs AO1 & AO2

Output range	0 to 20 mA (-0.2 mA to 21 mA, includes standard 4-20mA)
Maximum load	1000Ω
Resolution	0.4 μA
Response time	Loadcell response time setting + 20 ms
Voltage output	Use an external resistor to convert mA to volts. For example 500Ω gives 10 V at 20 mA.
Non-linearity	<0.01 %
Drift	<2 μA/°C.
Isolation	independently galvanically isolated to 50Vac
High voltage	> 8 V
Low voltage	< 4 V
Maximum voltage	32 V
Input load	4 kΩ approximate

Digital Inputs INx

High voltage	> 8 V
Low voltage	< 4 V
Maximum voltage	32 V
Input load	6 kΩ approximate
Input type	PNP output sensors

Digital Outputs OUTx

Max output current	$\Sigma I_{IOx} < 0.25 \text{ A}$
Output voltage	same as supply voltage

Communications COM1, COM2 & COM3

COM1 Interface	RS232
COM1 Handshake	CTS can be enabled
COM2/COM3 Interface	RS485
Baud rates	9600, 19200, 38400, 57600, 115200 (230400 on COM2)
Settings	8 data bits, no parity, 2 stop bits (8-N-2)
Protocol	Modbus RTU (MWBUS on COM2)

General

IP Rating	IP20 (MD1,MP1 facia IP65) (MD2,MP2 facia IP54)
Operating temperature	-10 to 45 °C
Supply voltage	10 to 28 Vdc
Power MT1	1.0 to 2.2 W + P _{Tacho Excitation}
Power MT3	1.0 to 2.2 W + P _{Tacho Excitation}
Power MR1	1.5 to 2.5 W + P _{OUTx}
Power MD1	1.8 W
Power MP1	1.8 to 3.0 W

Power MD2	1.4 W
Power MP2	1.4 to 3.1 W
Power MP2 + MO3	3.4 to 5.0 W + P _{OUTx} + P _{Tacho Excitation}
MP2 Restrictions	P _{Loadcell Excitation} + P _{AO1} + P _{AO2} < 1.5 W
	I _{Supply} < 0.5 A

Dimensions

Following are the dimensions of the hardware items that make up the system.

The displays/processors are designed for panel mounting.

MD2 Display

MP2 Processor

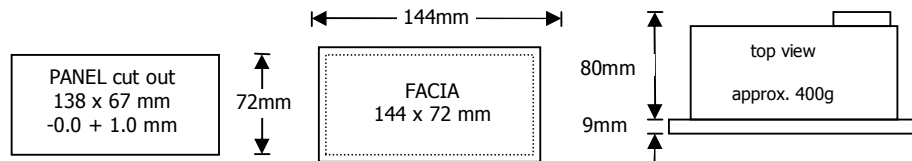

MD1 Display

MP1 Processor

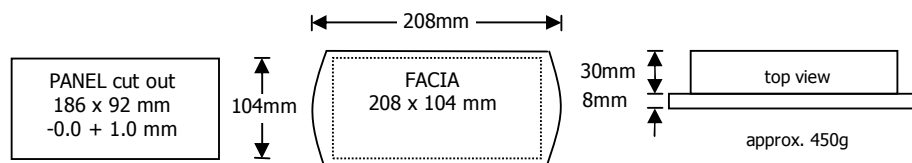

MT1 Transmitter

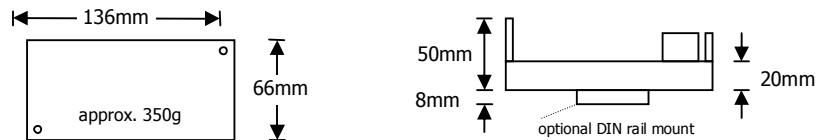

MT3 Transmitter

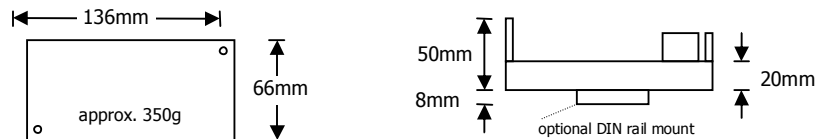

MR1 Remote IO

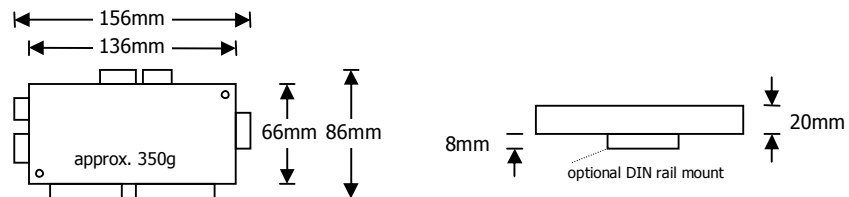

Connections

Connection Principles

ModWeigh instruments can be configured in many different ways to suit any given application. The display is normally located to suit an operator. The transmitter can be located in the field to reduce field wiring or can be located with the display for a more conventional approach. The I/O can conveniently be situated on a DIN rail in a cabinet.

Connection Diagram – MP2

Keep all wiring separated from mains wiring

Use shielded cable where indicated

Either the RUN input or the RUN MOTOR output should be used

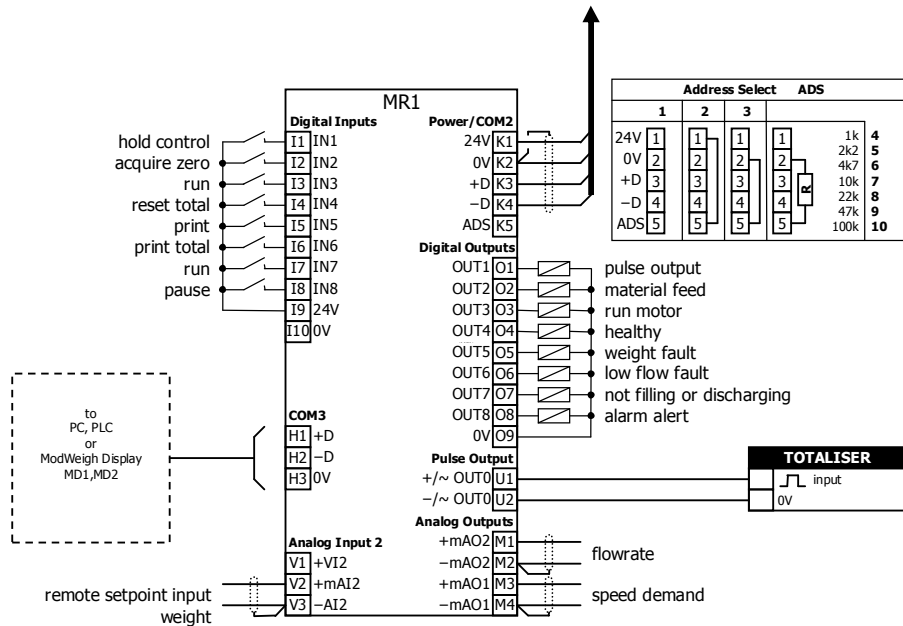
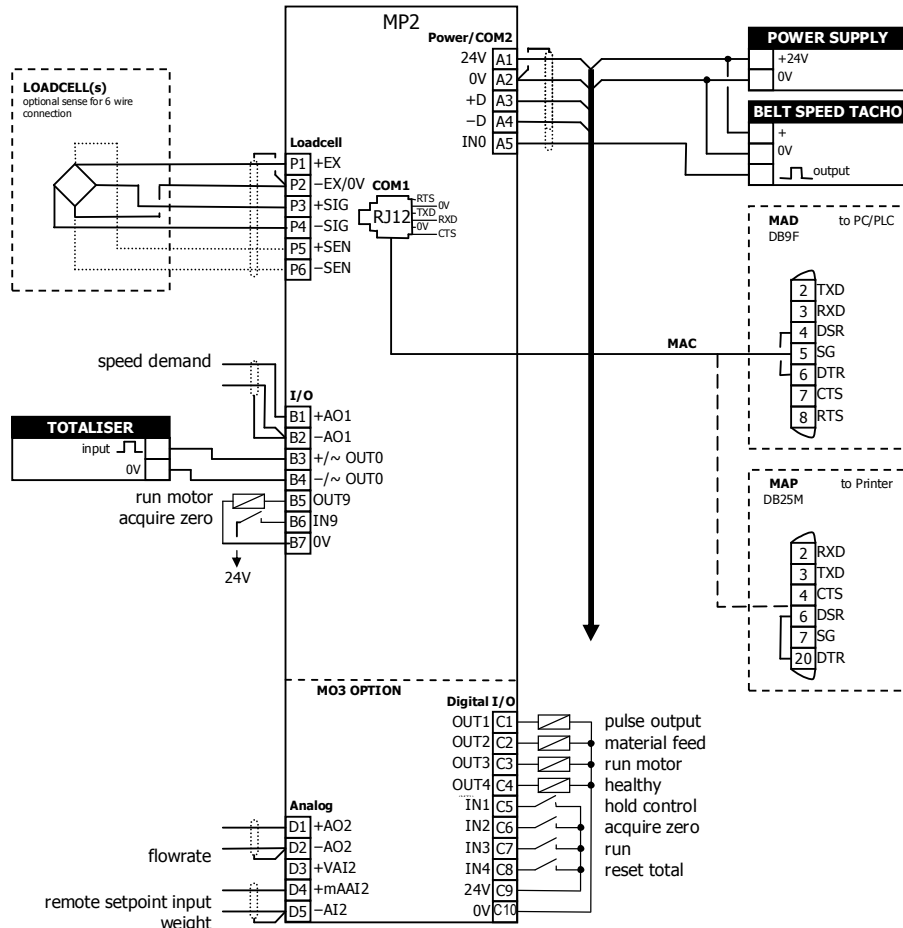

Connection Diagram – MP1

Keep all wiring separated from mains wiring

Use shielded cable where indicated

Either the RUN input or the RUN MOTOR output should be used

MP1 bus address set with setting (Q2522).

MR1 bus address set with ADS pin and must be same as MP1.

Fit an MAT terminator to each end of COM2 cable if length exceeds 50m.

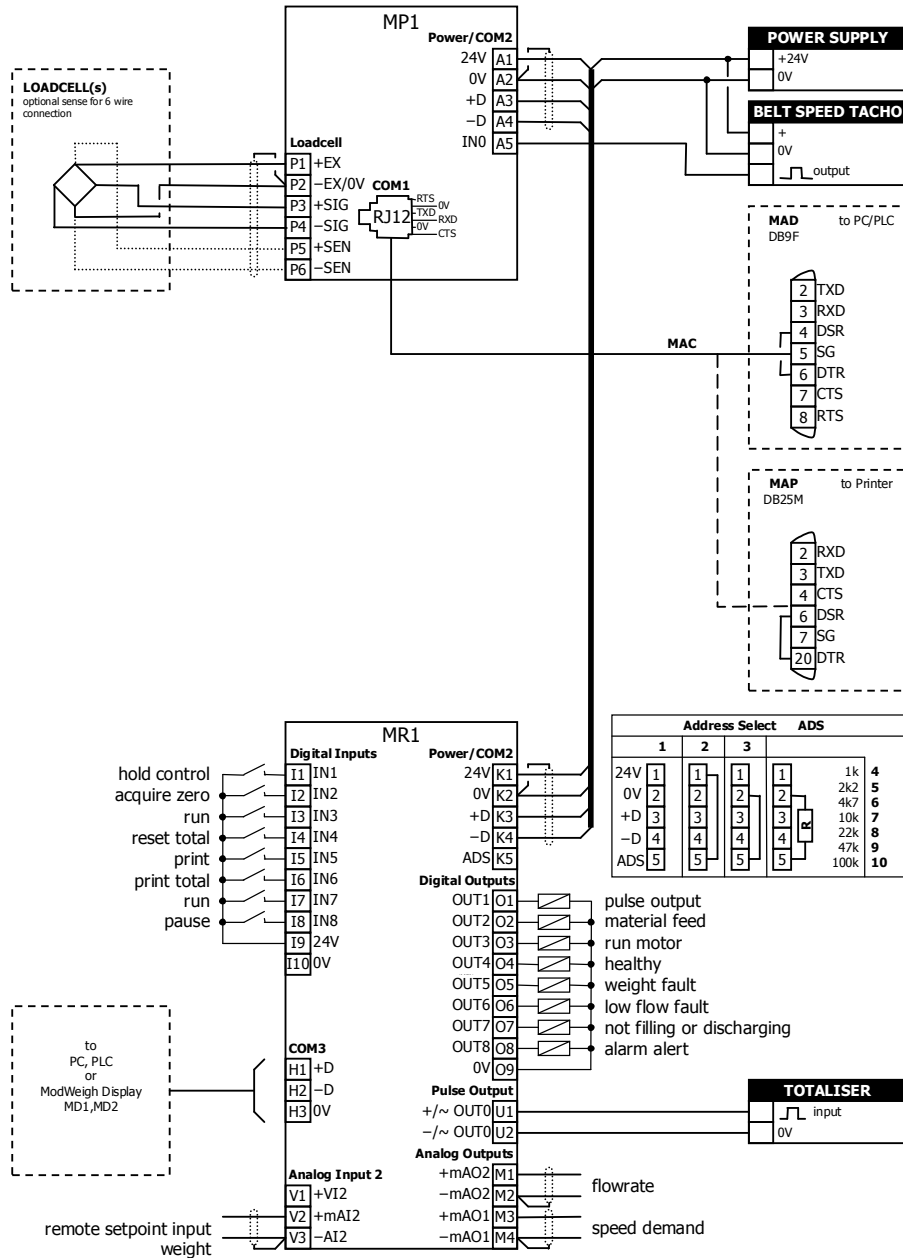

Connection Diagram – MT1

Keep all wiring separated from mains wiring.

Use shielded cable where indicated.

Either the RUN input or the RUN MOTOR output should be used.

For individual loadcell sensitivity adjustment, use terminals P, Q, R and S.

Display and transmitter can alternatively be connected COM1 to COM1 using an MAC cable.

MT1 bus address set with ADS pin or a setting.

MR1 bus address set with ADS pin and must be same as MT1.

Fit an MAT terminator to each end of COM2 cable if length exceeds 50m.

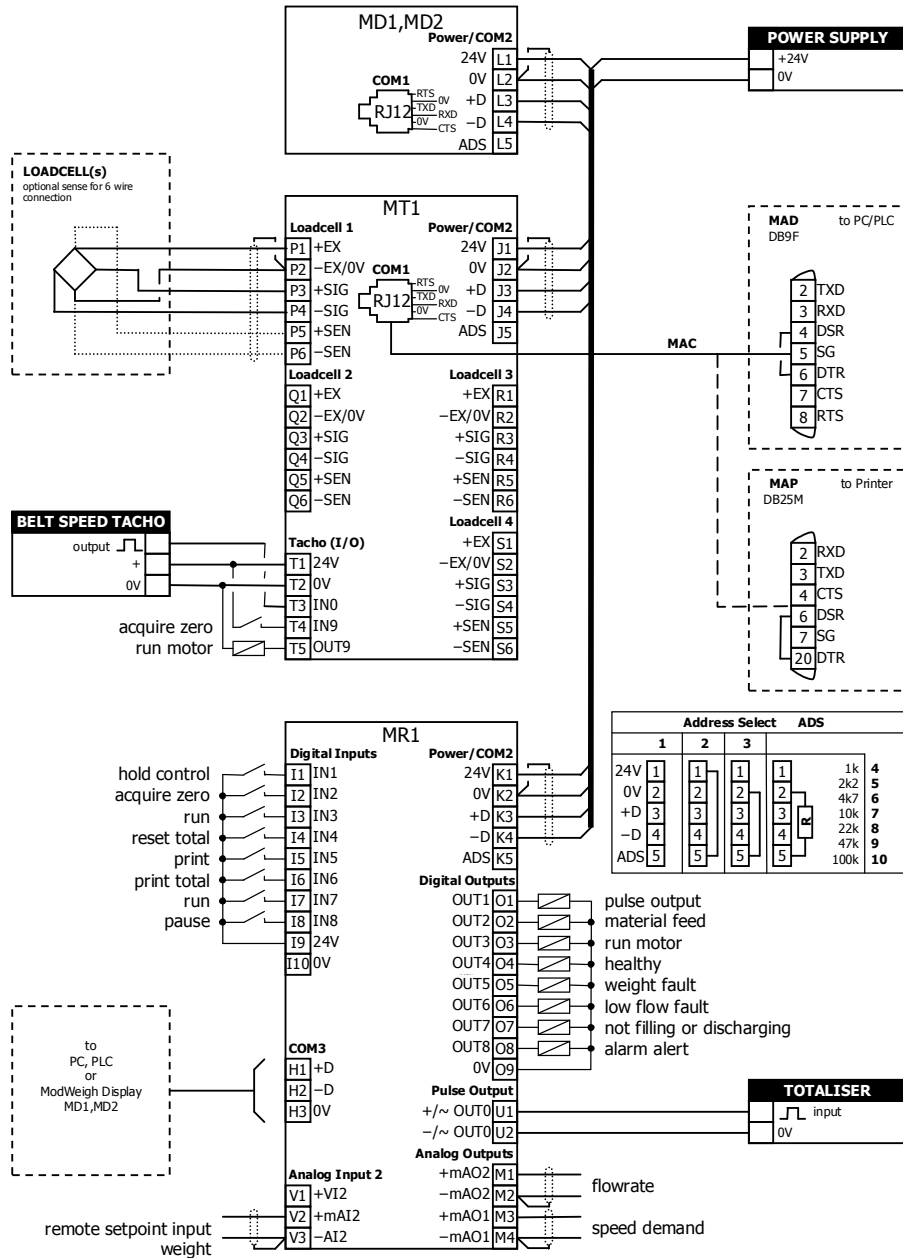

Connection Diagram – MT3

Keep all wiring separated from mains wiring.

Use shielded cable where indicated.

Either the RUN input or the RUN MOTOR output should be used.

Display and transmitter can alternatively be connected COM1 to COM1 using an MAC cable.

MT3 bus address set with ADS pin or a setting.

MR1 bus address set with ADS pin and must be same as MT3.



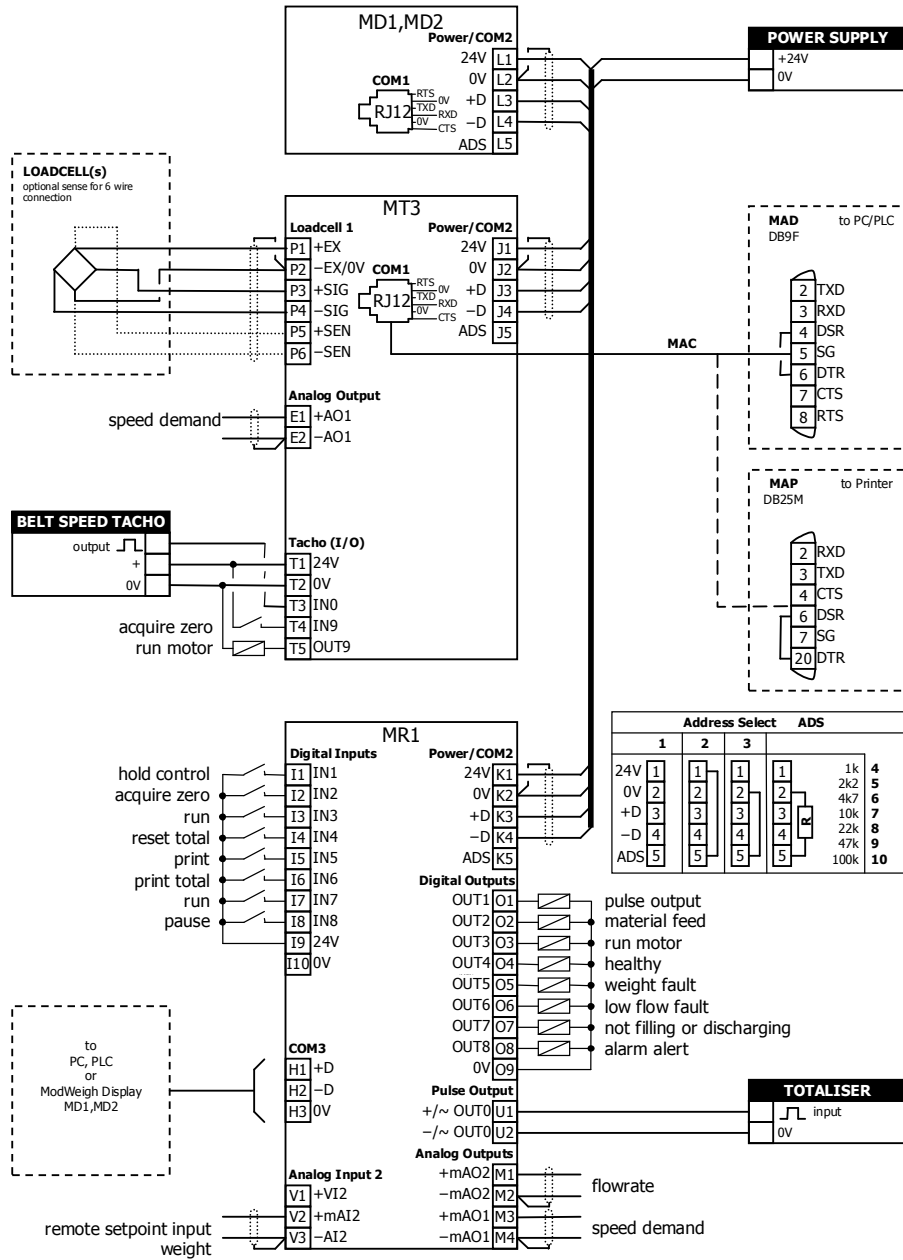



Fit an MAT terminator to each end of COM2 cable if length exceeds 50m.



Address Select				ADS
1	2	3	4	
24V	1	1	1	1k 4
0V	2	2	2	2k2 5
+D	3	3	3	4k7 6
-D	4	4	4	10k 7
ADS	5	5	5	22k 8
				47k 9
				100k 10

System Ordering

A ModWeigh system is a group of ModWeigh parts that together form the system. Many possible systems can be created, but most applications will use one of the systems listed below. When ordering, just specify the system order code. To create a custom system, specify the individual components required.

Weight Change Instrument	System Order Code
Product Key, Processor, IO 	MK93A,MP2,MO3
Product Key, Processor, IO 	MK93A,MP1,MR1
Transmitter, display, IO 	MW93A,MT3,MD1,MR1
Transmitter, display, IO 	MW93A,MT3,MD2,MR1
P-Module, transmitter, display, IO 	MW93A,MT1,MD1,MR1
P-Module, transmitter, display, IO 	MW93A,MT1,MD2,MR1

Parts Ordering

Following is a list of order codes for the individual parts of a ModWeigh system.

The order code (and options) are shown below.

Product

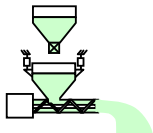
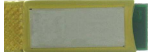

select one of the following	
P-Module (for transmitter only)	MW93A
Unactivated P-Module (requires a product key)	MX93A
Product Key	MK93A

Special Options



select any (or none) of the following	
Chinese manuals	,CH
Korean manuals	,KO
German manuals	,DE
Spanish manuals	,ES
French manuals	,FR
Italian manuals	,IT
Polish manuals	,PL
No manuals	,NM
Manufacturing certificate	,MC

Processor



select one (or none) of the following	
Loadcell processor	,MP2
Loadcell processor	,MP1
Loadcell transmitter	,MT3
Loadcell transmitter	,MT1

Transmitter



IO Option



select one (or none) of the following (only for MP2)	
digital IO - 4In 4Out, 1 x 4-20mA input & output	,MO3

Display



select one (or none) of the following	
4.3" Colour display	,MD1
2.8" Colour display	,MD2

Remote IO



select one (or none) of the following	
Remote IO unit	,MR1

Accessories



select one (or none) of the following	
RJ12 Cable 2m (COM1 cable)	,MAC
RJ12 to 9 pin D-connector adaptor (ModWeigh to PC)	,MAD
RJ12 to 25 pin D-connector adaptor (ModWeigh to printer)	,MAP
DIN Rail mount kit for MT1,MT3 or MR1	,MAR
Stack mount kit for MT1,MT3 or MR1	,MAS
RS485 Line Terminator	,MAT

Other ModWeigh Products

MW61 Weigher Systems – loadcells indicators. Suitable for scales, vessel weighing and most general weighing applications.

MW94 Impact Weigher Systems – impact weigher processor for continuous flowrate measurement.

MW95 Belt Weigher Systems – belt weigher processor for continuous flowrate measurement.

MW96 Weighfeeder Systems – weighfeeder processor for continuous flowrate control application of a weighing conveyor.

Contact Details



NEW ZEALAND

EMC INDUSTRIAL GROUP LTD

56 Tarnsdale Grove, Albany, North Shore, Auckland 0632

PO Box 101 444, North Shore, Auckland 0745, New Zealand

Phone +64-9-415 5110, Fax +64-9-415 5115

Email sales@emc.co.nz Web www.emc.co.nz



AUSTRALIA

ACTIVE WEIGHING SOLUTIONS

Unit 2 / 41-49 Norcal Road, Nunawading, VIC 3131, AUSTRALIA

PO Box 338, Box Hill, VIC 3128, AUSTRALIA

Phone +61-3 9873 7677, Fax +61-3 9873 7655

Email sales@activeweighing.com.au Web www.activeweighing.com.au

As we are continuously improving our products, changes to this specification may occur without notice.

(Document Details: g0 g1 g2 g3 g4 g5 g6 g7 g8 g9 g10 g11 g12 g13 g14 g15 MT1,MT3,MD1,MD2,MP1,MP2))